

Part Number	Description
3PAK220	1.1A, 250 Vac, 3-phase solid-state relay with status indication

MECHANICAL SPECIFICATION

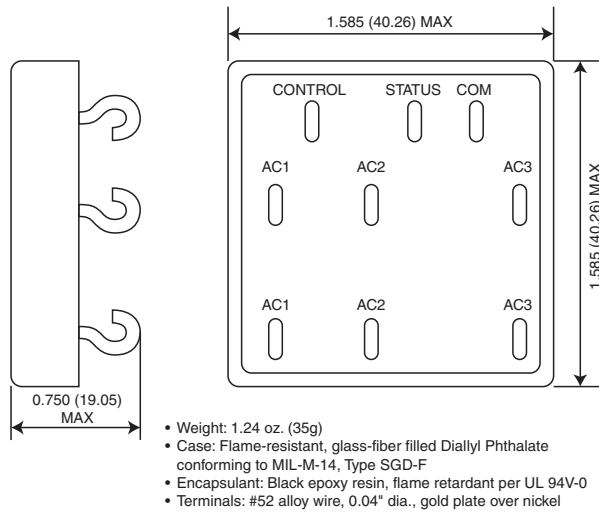

Figure 1 – 3PAK220 mechanical specification; dimensions in inches (mm)

INPUT (CONTROL) SPECIFICATIONS

(-40°C to +85°C unless otherwise noted)

	Min	Max	Units
Input Voltage		32	Vdc
Input Current @ 28 Vdc (See Figure 2)		20	mAdc
Must Turn-On Voltage	24		Vdc
Must Turn-Off Voltage		2	Vdc
Must Turn-Off Current		100	µAdc
Reserve Polarity	-32		Vdc



FEATURES/BENEFITS

- Low EMI
- No heat sink required
- ESD class 2 compliance per MIL-STD-833, method 3015
- Compliant with MIL-STD-704D, aircraft electrical power characteristics
- Status verification of the input command
- Optical isolation between input and outputs

DESCRIPTION

The Teledyne Relays 3PAK220 relay is a 3-phase, 250 Vac solid-state relay with status indication. It delivers 28 Vdc input and 1.1A output. Relay inputs and outputs are optically isolated.

The relay is a commercial-off-the-shelf (COTS) relay designed for 3-phase, 47–440 Hz applications where low EMI and reliable operation under conditions of severe environmental stress are a requirement.

Electromagnetic interference compliant per the requirements of MIL-STD-461 and MIL-STD-462. This relay component passes “in-system” EMI testing for conducted emissions per test methods CE01, CD02 and CE04; for conducted susceptibility per CS01, CS02 and CS06; and for radiated susceptibility per RS02 and RS03.

OUTPUT (LOAD) SPECIFICATIONS

(-40°C to +85°C unless otherwise noted)

	Min	Max	Units
Load Voltage Range	250	Vac	
Current Range	0.1	1.1	Arms
Frequency	47	440	Hz
Leakage Current @ 208 Vac, 400 Hz	7.5	mArms	
Transient	-550	550	Vpeak
dv/dt	850	V/μs	
Output Voltage Drop	1.5	Vrms	
Surge Current (25ms)	25	Apeak	

STATUS SPECIFICATIONS

(-40°C to +85°C unless otherwise noted)

	Min	Max	Units
Status Voltage		32	Vdc
Status Current		10	mA
On-State Voltage Drop		0.4	Vdc
Turn-On Time		20	ms
Turn-Off Time		20	ms

STATUS TRUTH TABLE

Relay Input Voltage	Status Output
<2 Vdc	low (<0.4 Vdc)
>24 Vdc	high (= status supply voltage)

ENVIRONMENTAL SPECIFICATIONS

	Min	Max	Units
Operating Temperature	-40	+85	°C
Storage Temperature	-55	+85	°C
Dielectric Withstanding Voltage (DWV) (sea level)	1500		Vac
DWV (20,000 feet)	700		Vac
Insulation Resistance	1x10 ⁸		Ohm
ESD	MIL-STD 883, method 3015 Class 2		
EMI	CE01, CE02, CD04, CS01, CS02, CS06, RS02, RS03		
Resistance to Soldering Heat	MIL-STD 202, method 210		
Solderability	MIL-STD 202, method 208		
HAST	85%RH, 93°C, 96 hours non-operating		
Moisture Resistance	MIL-STD 883, method 1004		
Random Vibration	MIL-STD 810D, method 514.3, category 6		
Gunfire Vibration	MIL-STD 810D, method 519.3		
Shock	MIL-STD 810D, method 516.3, procedure 1		
Altitude (Non-Operating)	50,000		ft.

INPUT CURRENT VS. VOLTAGE

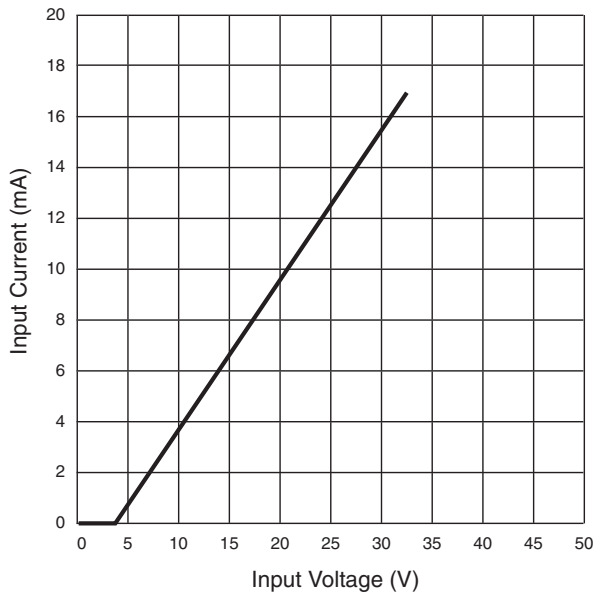

Figure 2 — 3PAK220 input current vs. voltage

STATUS CURRENT VS. VOLTAGE

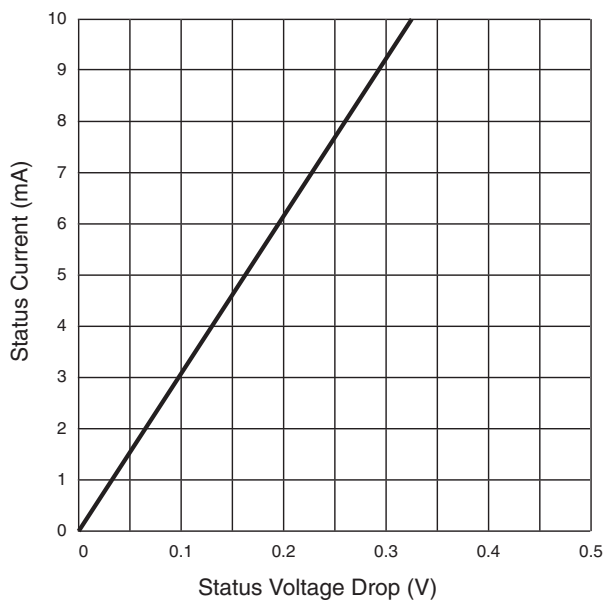

Figure 3 — 3PAK220 status current vs. voltage

FUNCTIONAL DIAGRAM

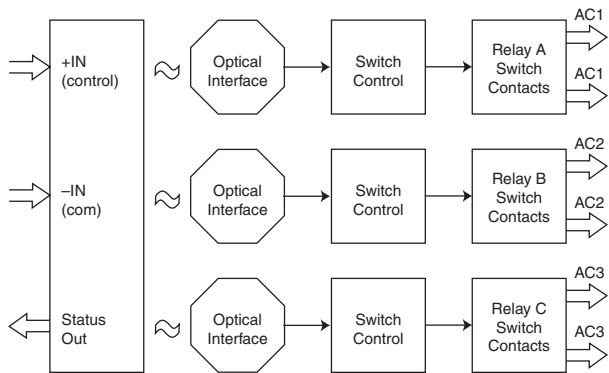

Figure 4 — 3PAK220 functional diagram

TYPICAL WIRING DIAGRAM

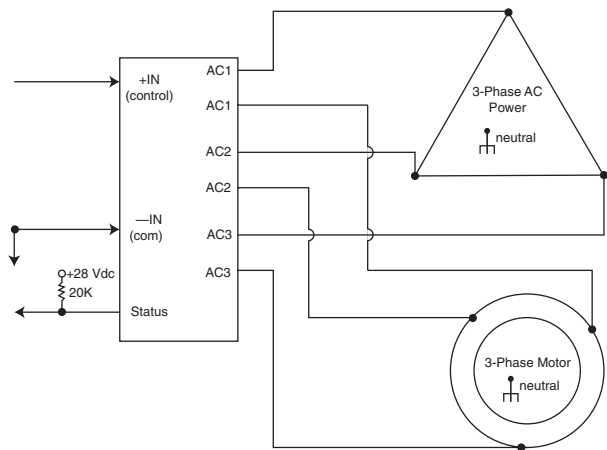

Figure 5 — 3PAK220 typical wiring diagram

OPTIONAL MOUNTING FLANGE

OPTIONAL MOUNTING FLANGE ATTACHED
ORDER PART: 3PAK220F

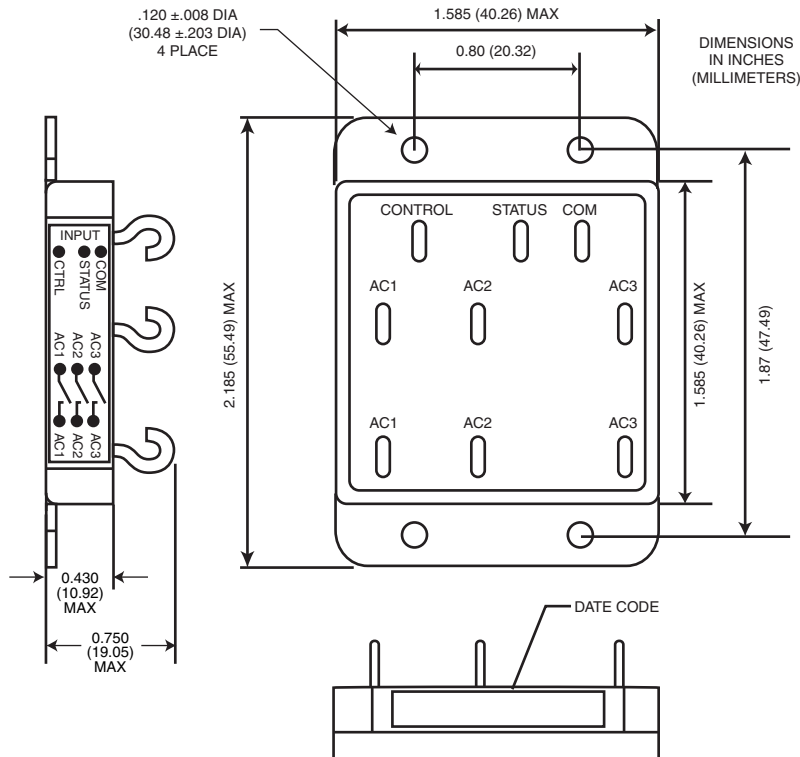

Figure 6 — 3PAK220 optional mounting flange